

NOTES: UNLESS OTHERWISE SPECIFIED

1. SEE DRAWING NO. CB-00281 AND PROCEDURE P-1000 FOR ASSEMBLY AND TEST INSTRUCTION. PROCEDURES AND ASSEMBLY DRAWINGS ARE FOR INTERNAL USE ONLY.
2. ALL TESTING IS PERFORMED IAW BATTERY COUNCIL INTERNATIONAL STANDARDS.
3. DIMENSIONS ARE INCH [MILLIMETER].
4. ABBREVIATION USED IN TITLE IS: SEALED LEAD ACID (SLA).
5. TERMINAL HARDWARE KIT PROVIDED, PART NUMBER 6923 (2 REQD).

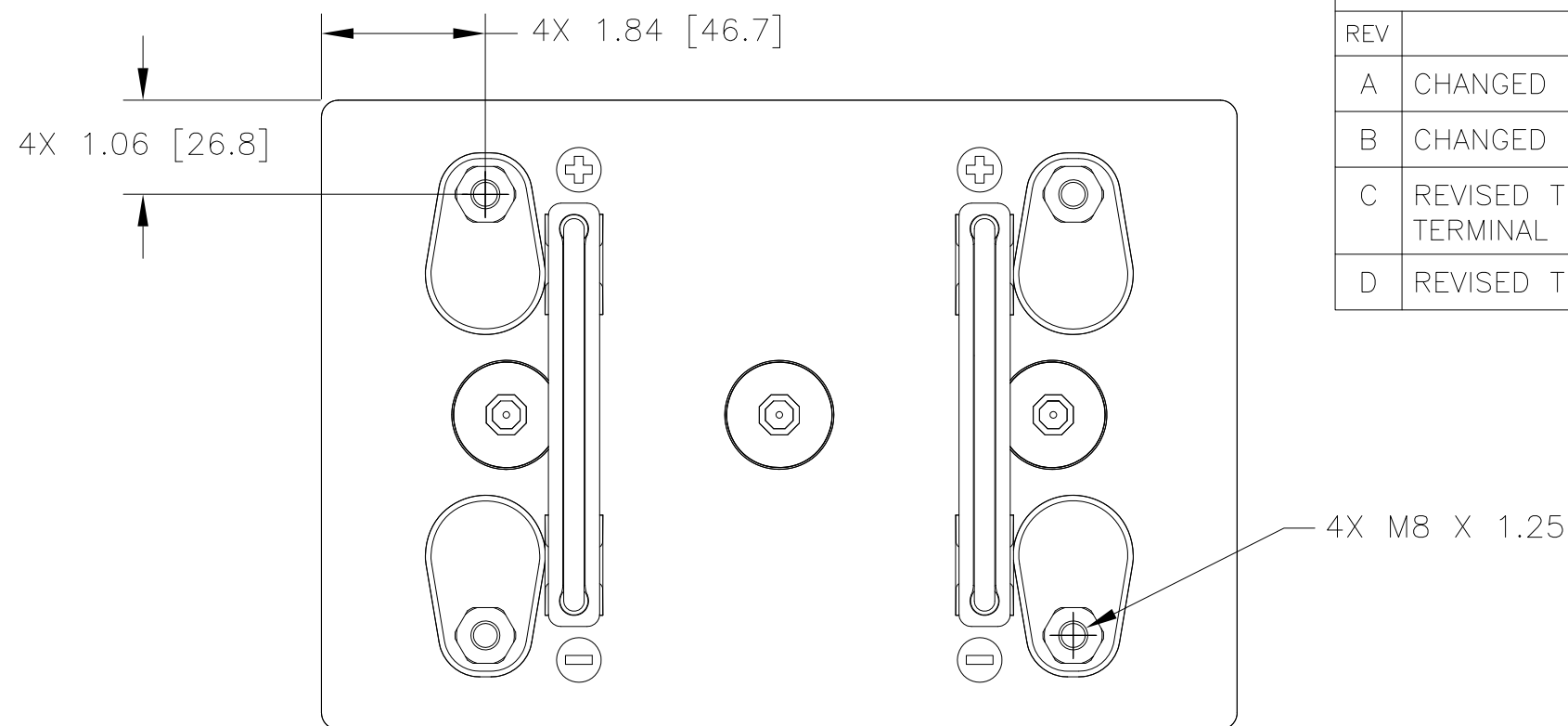

REVISIONS			
REV	DESCRIPTION	DATE	APPROVED
A	CHANGED HANDLE DIRECTION	2/26/07	JBT
B	CHANGED COVER & HANDLE	11/6/07	JBT
C	REVISED TERMINAL DAMS, TERMINAL HEIGHT & HANDLES	9/16/09	JBT
D	REVISED TERMINAL HEIGHT	6/12/20	PH

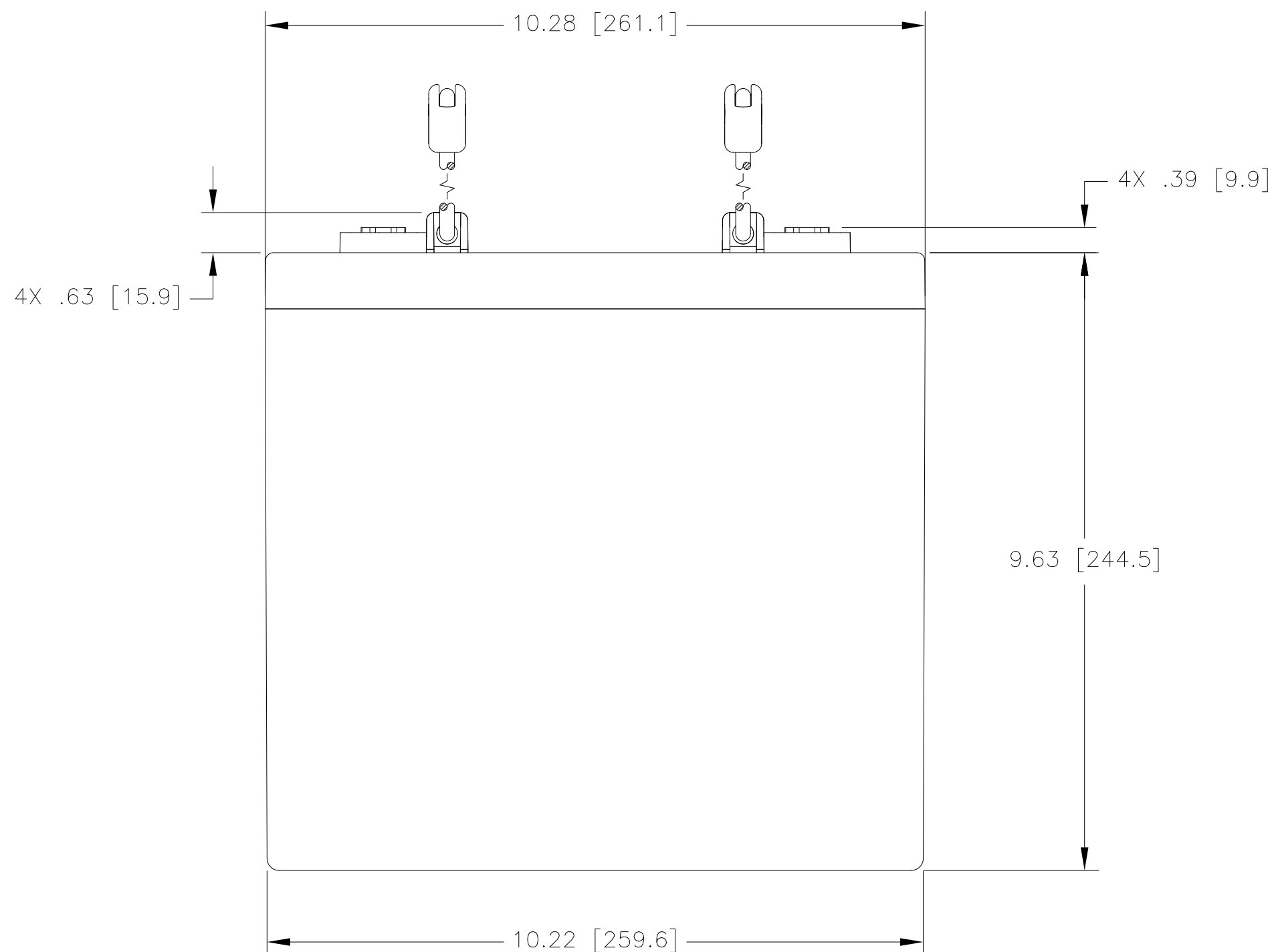
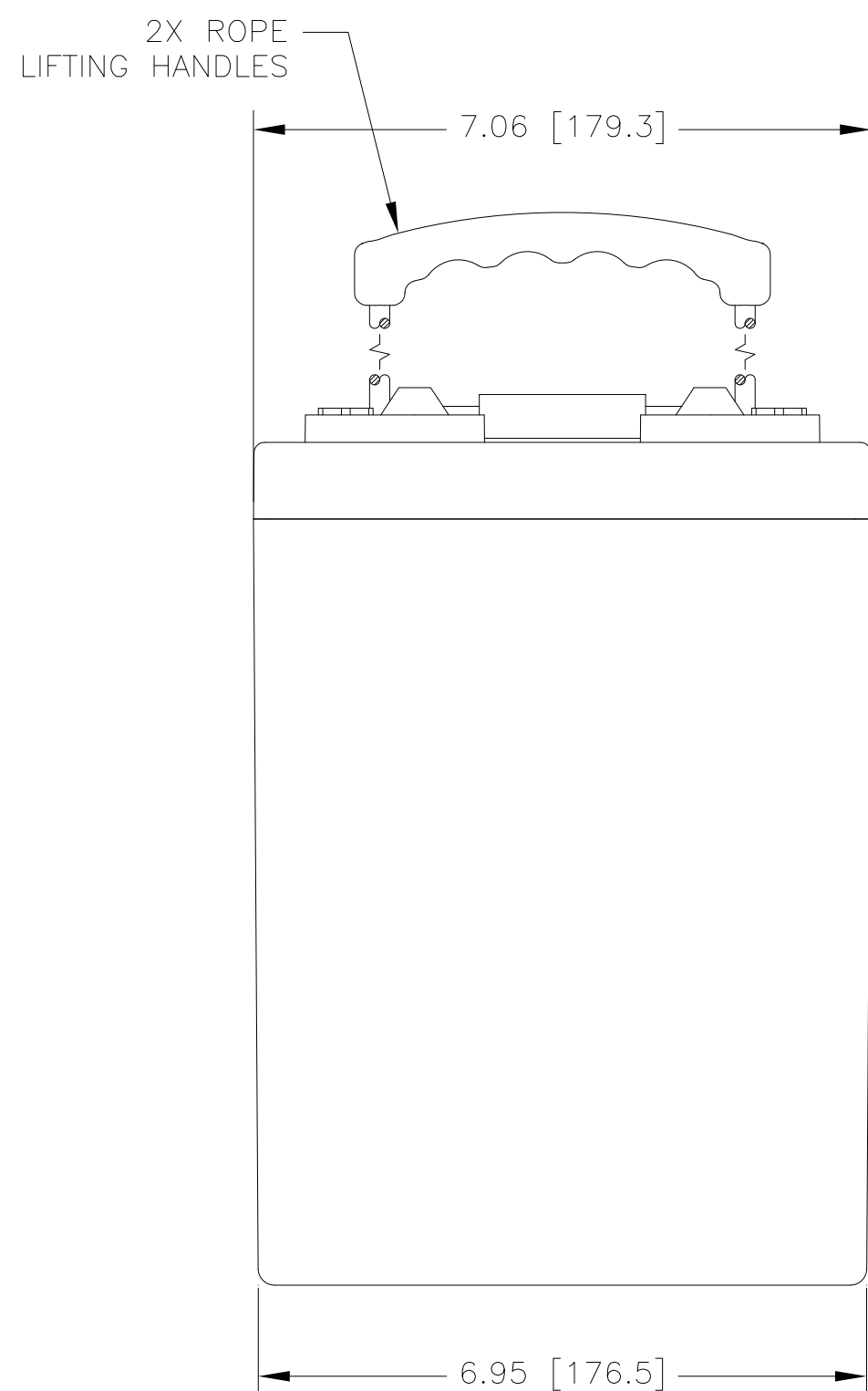

ENVELOPE DRAWING

CAPACITY RATINGS	
PART NUMBER	PVX-6720T
NOMINAL WEIGHT	70 LBS [31.8 KG]
AMPERE HOUR CAPACITY @ 24 HOUR 1.75 VOLTS/CELL @ 77°F (25° C)	672 AH

QTY REQD	CAGE CODE	PART OR IDENTIFYING NO.	NOMENCLATURE OR DESCRIPTION	MATERIAL SPECIFICATION	ITEM NO.
PARTS LIST					
UNLESS OTHERWISE SPECIFIED DIMENSIONS ARE IN INCHES TOLERANCES ARE:			CONCORDE BATTERY CORPORATION 2009 SAN BERNARDINO RD, W. COVINA, CA 91790		
FRACTIONS	DECIMALS	ANGLES	APPROVALS	DATE	TITLE
± 1/32	.XX ± .12	± 1°	DRAWN D AYALA	12/19/06	BATTERY, SLA, 2 VOLT, PVX-6720T
	.XXX ± .060		CHECKED AMIII	1/9/07	SIZE C
TREATMENT	NONE	APPROVED	JBT	1/10/07	CAGE CODE 63017
FINISH	NONE	ISSUED	DH	6/12/20	DWG NO. PVX-6720T
SIMILAR TO	ACT WT	CALC WT			REV D
			SCALE 1/2	SHEET 1 OF 1	